



Wind & Solar
Renewable Energy Experts

Distributors of:

REGEN™
RENEWABLES



ReGen 700W 5 blade Wind Turbine

Rated Power	700W
Maximum Power	720W
Rated Voltage	48V
Start-up Wind Speed	2.5m/s (9km/h)
Rated Wind Speed	11m/s (39.6km/h)
Survival Wind Speed	45m/s (162km/h)
Nett Weight	23kg
Wheel Diameter	1.85m
Number of Blades	5 Blades
Blade Material	Reinforced glass fibre
Generator	3 phase permanent magnet AC
Magnet	NdFeB
Generator Case	Die-cast aluminium
Control System	By controller
Direction Regulation	Automatically adjusts windward
Working Temperature	-40°C~80°C
Packaging Dimensions	120cm x 39.5cm x 30cm
Warranty	Standard 2-year Carry-In Warranty
Brochure updated	2021-01-15

Flange Dimensions

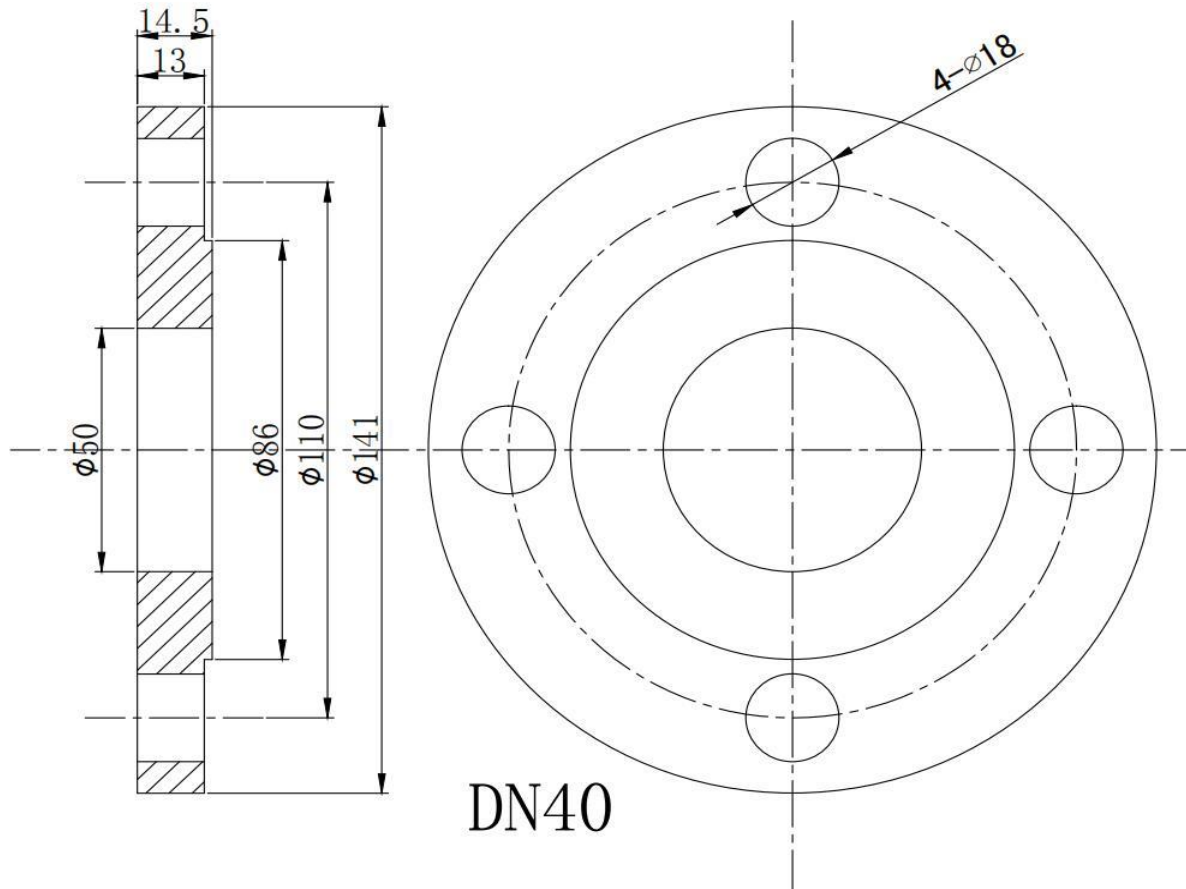

Warranty

Wind and Solar (Pty) Ltd provides a carry-in Limited Warranty from the date of shipment. The Warranty period on various products are as follows:

Wind Turbines:

The ReGen LX series Turbines have a 3 Year carry-in warranty from date of shipment.

The ReGen S, M and L Series Turbines have a 2 Year carry-in warranty from date of shipment.

Controllers:

ReGen Turbine controllers all have a 1 Year carry-in warranty from date of shipment.

The warranty covers all parts of the wind turbine damaged within the warranty period and free replacement part/s. A complete wind turbine will only be provided after remote troubleshooting and analysis of the problem by Wind and Solar (Pty) Ltd technicians. Wind and Solar (Pty) Ltd holds the right to provide the most appropriate solutions in terms of parts, complete turbine replacement & by means of shipment.

Conditions:

1. We warranty this product against defects in materials and workmanship from the date of purchase and will repair or replace any defective unit when directly returned, postage paid, to Wind and Solar (Pty) Ltd. This warranty will be considered void if the unit has suffered any obvious physical damage or alteration either internally or externally.
2. This warranty does not cover damage arising from improper use, such as plugging the unit into unsuitable power sources, attempting to operate products that require excessive power consumption, or use in unsuitable environments.
3. This warranty does not cover Wind turbines that have not been installed, operated, repaired, or maintained in accordance with instructions supplied by Wind and Solar (Pty) Ltd.
4. This warranty does not cover Wind turbines or wind controllers that have been:
 - a. Altered and/or modified in any way.
 - b. Damaged caused by abnormal physical, thermal or electrical stress, negligence, misuse.
 - c. Damage caused by force majeure events like lightning, storms, hurricane force winds, flood, earthquake etc.
 - d. Damage caused using any unauthorized controller, inverter or tower not provided or confirmed by Wind and Solar (Pty) Ltd.

This is the only warranty the company makes. No other warranties express or implied including warranties of merchantability and fitness for a particular purpose. Repair and replacement are your sole remedies and the company shall not be liable for damages, whether direct, incidental, and special or consequential, even if caused by negligence.

Further details about our warranty conditions can be found at www.windandsolar.co.za

Liability Exclusion:

The manufacturer shall not be liable for damages, especially on the battery, caused by use other than as intended or as mentioned in this manual or if the recommendations of the battery manufacturer are neglected. The manufacturer shall not be liable if there has been service or repair carried out by any unauthorized person, unusual use, wrong installation, or incorrect system design.

Warranty Claim Procedures:

In order to get service under this warranty, the customer must provide Wind and Solar (Pty) Ltd with the following information for analysis:

1. Serial number of wind turbine, running time & malfunction date.
2. Detailed description of the defects and corresponding test results which have been done in accordance with the troubleshooting Wind and Solar provide.
3. A Wind and Solar technician may ask for some extra testing in order to identify the defects so that solutions can be provided promptly and precisely. The installer or customers are liable to conduct these extra tests and provide referable test results.
4. Installation pictures (showing details of the installation location and its surrounding).
5. Damaged machine pictures and/or videos.
6. A Wind and Solar technician will provide a final solution according to defect description and the test results of the troubleshooting.

NOTE: The Customer is responsible for shipping the defected or damaged part to Wind and Solar for repair(s) if needed. Wind and Solar will then repair or replace the items covered by the warranty for free and ship it back to the owner at Wind and Solar's cost. If no defective items are shipped back to Wind and Solar but needs replacement - Wind and Solar will provide the part for free but shipping will be at the customer's expense.